

GENERAL DESCRIPTION AND DATA

Dellner Brakes spring applied, hydraulically released disc brake, model SKP 180A offers a reliable and safe method of braking linear or rotary motion.

The brake consists of two symmetrical cylinder Housings and can be supplied with or without a mounting stand.

Each Housing has two cylindrical guide pins that transmit the tangential braking force from the brake lining to the brake housing and mounting stand. As a result, the brake pistons are not subject to any radial forces which contribute to longer brake life.

Four springs on each brake half retract the brake pads from the disc when pressure is applied.

The disc spring pack must be adjusted to compensate for brake lining wear and to maintain full brake capacity. An extension of the brake piston through the adjustment nut gives an easy visual way to tell when adjustment is needed.

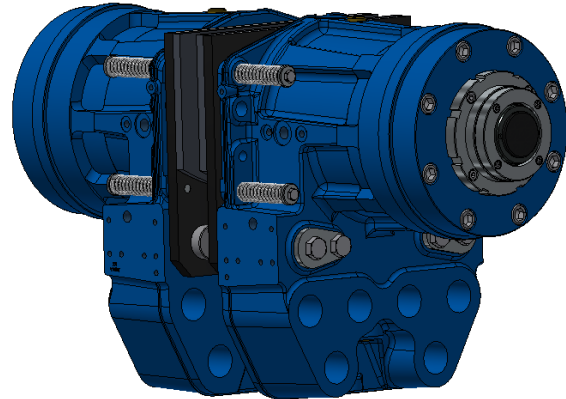

Size	Tangential braking force F [N] ¹⁾		Releasing pressure [bar] ⁴⁾	Balancing pressure [bar] ⁵⁾	Air gap between brake disc and lining [mm]		Estimated life of disc spring pack [no. of strokes]		Weight [kg]
	min. ²⁾	max. ³⁾			min. ⁶⁾	max. ⁷⁾	min. ⁸⁾	max. ⁹⁾	
SKP 180A-100	100 800	141 000	130	95	2x 2,0	2x 4,0	> 2x10 ⁶	> 2x10 ⁶	315
SKP 180A-130	131 100	170 300	155	115	2x 2,0	2x 4,0	> 2x10 ⁶	701 000	
SKP 180A-170	170 300	208 300	180	140	2x 2,0	2x 4,0	1 590 000	136 000	
SKP 180A-190	189 400	226 800	190	155	2x 2,0	2x 4,0	593 000	45 000	

All sizes within range has a: total friction area of 1200 cm² / total allowable wear volume of 1200 cm³

- 1) Calculated with an average frictional coefficient $\mu=0,42$. Consideration has not been taken for external factors.
- 2) Braking force with maximum recommended air gap before adjustment is needed.
- 3) Braking force with correctly adjusted disc spring pack.
- 4) Pressure to fully release brake.
- 5) Nominal pressure to balance an adjusted brake.
- 6) Air gap for correctly adjusted brake.
- 7) Maximum recommended air gap before adjustment is needed.
- 8) Valid for minimum spring pack travel.
- 9) Valid for maximum spring pack travel.

OPTIONS (*do not hesitate contacting us for more detailed information*)

- Brake pads with various friction material.
- Support in various design (single and/or double assemblies).
- Spacers for various brake disc thickness.
- Tube connection set (connects the Housings to one connection point).
- Various cylinder sealing concept (adapt to various hydraulic fluids and/or ambient conditions such as low and/or high temp.)
- Secondary cylinder sealing concept.
- Electrical indicators (brake ON/OFF, and/or NEED OF ADJUSTMENT, and/or pad WEAR)

DIMENSIONS (WITHOUT SUPPORT)

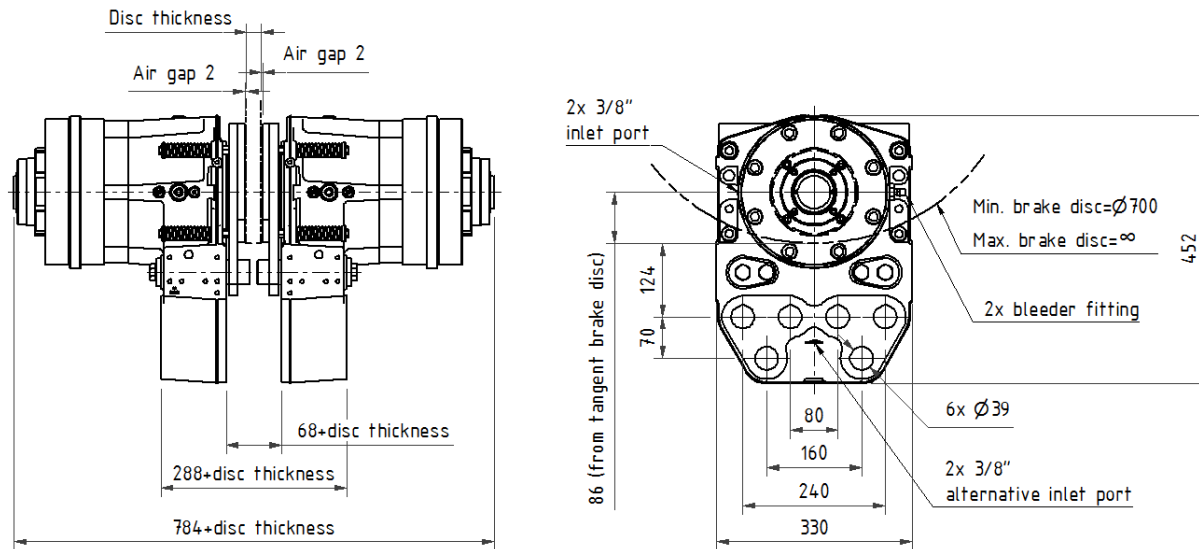

Minimum Brake Disc diameter $\phi D = 700$ mm
 Maximum Shaft flange diameter = Brake Disc diameter $\phi D - 440$ mm

TORQUE TABLE

Brake torque is calculated by using following formula:

$$M_{brake} = \frac{q \times F \times (D_s - H)}{2}$$

D_s = brake disc diameter [m]

$H = 0.172$ [m]

q = number of brakes

F = braking force, according to product leaflet [N]

Values in below torque table are shown in [Nm].

Size	Braking force F [N] ¹⁾	Disc diameter ϕD [mm]								
		$\phi 800$	$\phi 1000$	$\phi 1200$	$\phi 1500$	$\phi 1600$	$\phi 1800$	$\phi 2000$	$\phi 2250$	$\phi 2500$
SKP 180A-100	100 800	31 600	41 700	51 800	66 900	71 900	82 000	92 100	104 700	117 300
	141 000	44 200	58 300	72 400	93 600	100 600	114 700	128 800	146 400	164 100
SKP 180A-130	131 100	41 100	54 200	67 300	87 000	93 600	106 700	119 800	136 200	152 600
	170 300	53 400	70 500	87 500	113 000	121 500	138 600	155 600	176 900	198 200
SKP 180A-170	170 300	53 400	70 500	87 500	113 000	121 500	138 600	155 600	176 900	198 200
	208 300	65 400	86 200	107 000	138 300	148 700	169 500	190 300	216 400	242 400
SKP 180A-190	189 400	59 400	78 400	97 300	125 700	135 200	154 100	173 100	196 700	220 400
	226 800	71 200	93 800	116 500	150 500	161 900	184 600	207 200	235 600	263 900

1) Tangential Braking Force (F) calculated with an average frictional coefficient $\mu=0,42$. Consideration has not been taken for external factors. Values shown represent braking force with correctly adjusted disc spring pack (max.), respectively time to adjust (min).

APPLICATIONS

Dellner Brakes model SKP 180A is suitable wherever safety brakes are needed, for example in the following types of applications:

- Cranes
- Winches
- Conveyors
- Wind mills
- Draglines
- Draw works